

CONTENTS

01 About Us

02 Ladle

03 Ladle Purging System

04 Purging Plug

05 Housing Block and set

06 Lance

07 Ladle Gate refractories

08 Well Block

09 Inner Nozzle and Collector Nozzle

10 Ladle Slide Gate plate

11 Assembled Slide Gate and Collector Nozzle

12 Ladle Filling Mass

13 Tundish

14 Tundish Plaster

15 Tundish gate refractories

16 Tundish Nozzle & Well Block

17 Tundish Slide Gate

18 Tundish Precast Shapes

19 Electric Arc Furnace (EAF)

20 EAF Roof

21 Refractory Alumina Mixes and Mortars

23 Insulating

23 Gunning

24 Regular Cement Castable

25 Low cement Castable

25 PLC (Palar Low Cement Castable)

26 PLC-Sf (Palar Low Cement Castable- Self Flow)

27 PLC-SP (Palar Low Cement – Spinel Content)

27 PLC-Cr (Palar Low Cement – Chromite Content)

27 PLC-AN (Palar Low Cement – Andolozite Content)

28 Ultra-low Cement Castable

29 Mortar

30 CUSTOMERS

31 Honors And Certificates

ABOUT US

PALAR SANAT REFRACTORY CO.

Since 1992, Palar Sanat company (PSC) has been active in the research, development, and production of refractory products and has been paving the road for major steel manufacturers in Iran for years. Relying on the creativity and knowledge of local engineers, Palar Sanat has been successful in identifying the needs of the steel industry and has been expanding its products basket accordingly.

- 1992: Ladle Filling Mass
- 1993: Well Block & Argon Lance
- 1994: Repairing Slide Gate Plates
- 1996: Assembling Slide Gate Plates
- 2005: EAF Roof
- 2010: Mortar
- 2011: Purging Plug
- 2016: Slide Gate Plate

Production of Slide Gate Plates has been a profound success for the R&D team at PSC. Other important products of the company include internal and external Nozzle (Inner & Collector Nozzles), Blocks and Well Blocks, Purging Plugs, lances, Precast Shapes, Alumina Castable, and Mortar.

Ladle Gate mechanism, as an important system in the continuous casting process, is used to control the flow rate of molten steel precisely and safely from Ladle into Tundish. Slid Gate Plate in this system has been regarded as the key unit as they will have to contact with molten steel and slag in long-time and will be subjected to corrosion of molten steel and slag, physical corrosion, and thermal impact. So, Slide Gate Plate should feature high spalling resistance, good corrosion resistance, and high thermal shock resistance.

Palar Sanat became a knowledge-based company and obtained 9001-14001 and 45001 standards from Switzerland in addition to SGS and CE certificates from QMS Italy as a superior industrial company. PSC was also selected a consumer rights advocate in Isfahan. The company is honored to be a member of Iranian Refractory Industry Association, Iran-Europe Green management, the research and Technology Network of Isfahan province, and the World Energy Foundation Certificates.

LADLE

Ladle Purging System
Ladle Gate refractories
Ladle Filling Mass

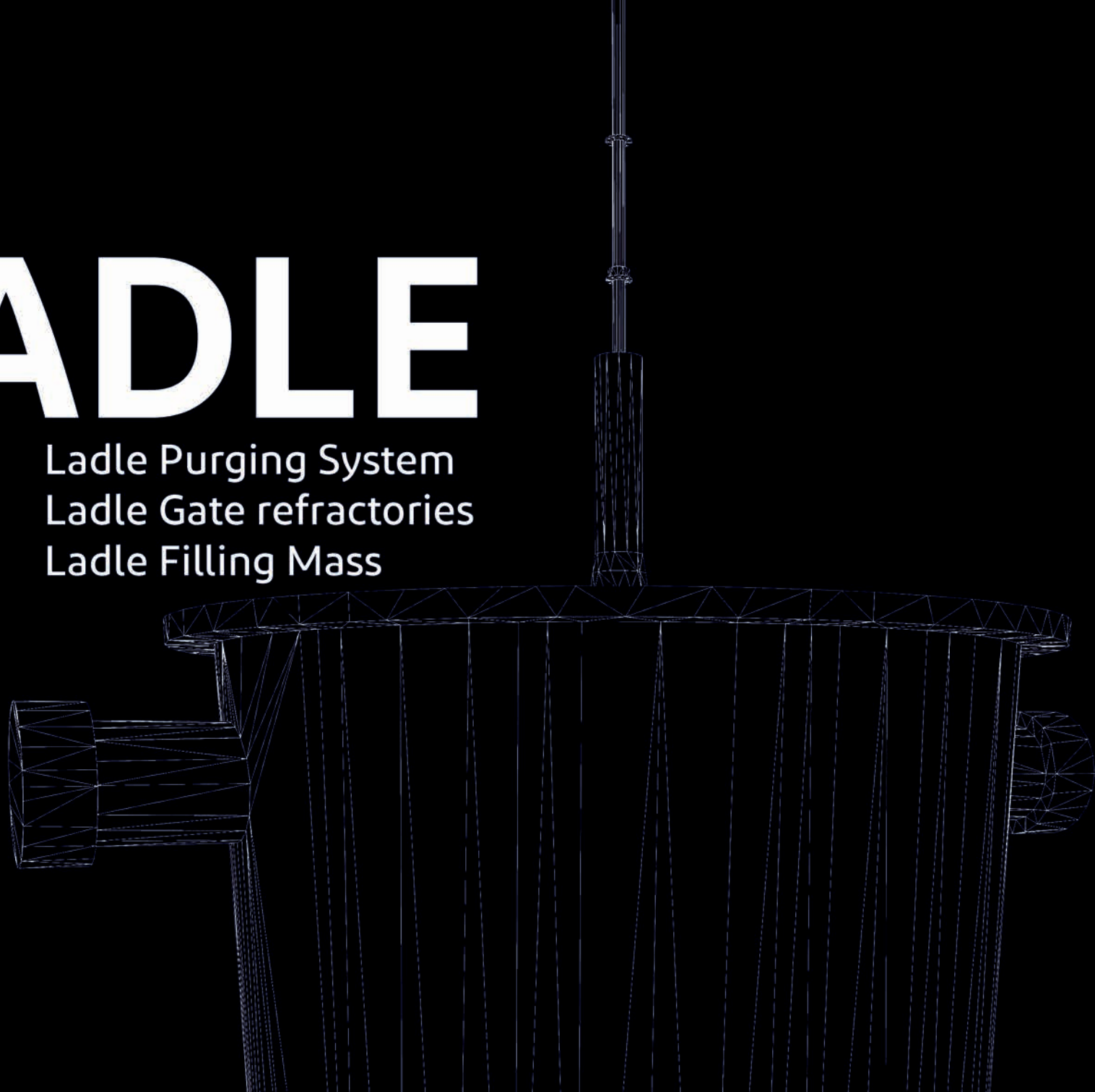



LADLE PURGING SYSTEM

Palar Sanat is a leader producer of Ladle purging refractories and systems, which include purging plug and lance. Our products are manufactured in different types customized to the Iron and Steel Companies' requirements.

The main purposes for purging system are:

- Desulfurization
- Uniform distribution of temperature
- Reduction of impurities
- Uniform distribution of alloy additives



Purging Plug

Applying advance technical design and top-quality material, PSC produces purging plugs that outperforms many competing domestic and foreign products, while providing long life, safety, and suitable initial opening rates.

Type of Palar Sanat Purging Plugs:

	Hybrid plug	Slot plug	Star plug	Segment plug
Optimum product for	High grade steel	Low alloy steel	High grade steel	High grade steel
Type	Multi piece	Single piece	Multi piece	Multi piece
Structure	Fired inserts cast	Cast	Fired inserts cast	Pressed and Fired inserts cast
Main raw material	Al ₂ O ₃ (with or without spinel and chromite)	Al ₂ O ₃ (with or without spinel and chromite)	Al ₂ O ₃ (with or without spinel and chromite)	Al ₂ O ₃
Initial Opening rate	Excellent	Good	Very good	Excellent

- PSC Ladle plug can be used in all types of Ladles with various capacities.



Housing Block and set

Housing block is maintaining a Ladle purging plug at the bottom of the Ladle.

In order to achieve important features such as high corrosion & erosion resistance, thermal shock resistance, and longer lifetime, Palar Sanat has produced special products by using high-quality materials such as PLC93sp, PLC95sp, PLC97.

Furthermore, to reduce risks in steelmaking plants, Palar Sanat has started to supply preassembled sets (Porous & Block) with high-quality mortar, that provides the following advantages:

- Easy to transport
- Easy to use
- High accuracy installation

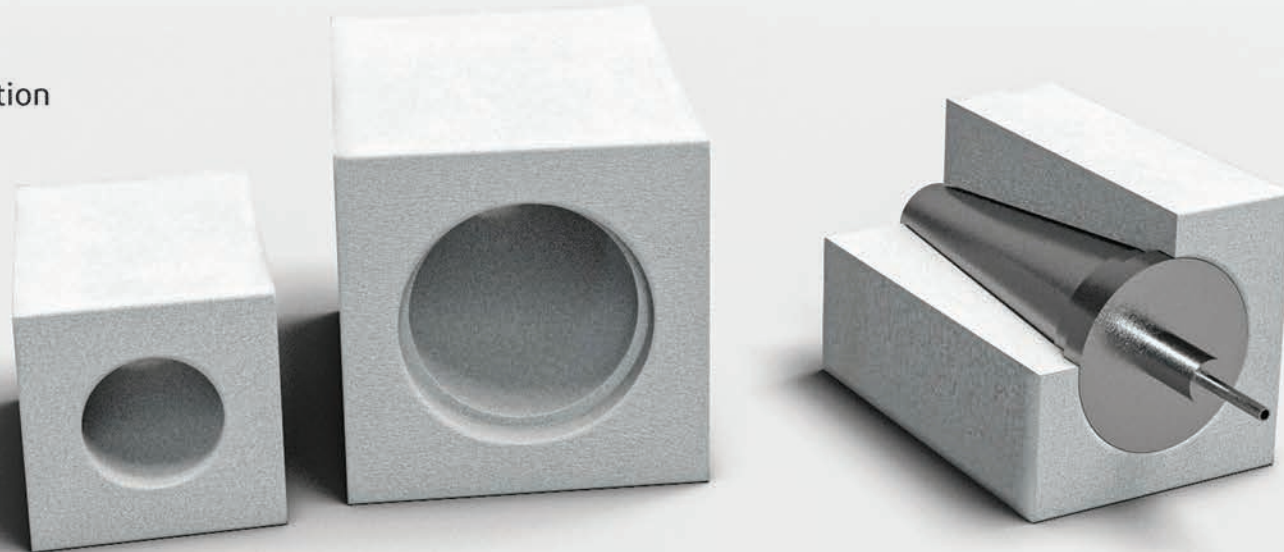

Lance

Palar Sanat lances are designed and manufactured for the following applications:

- Gas purging
- Gas and powder purging

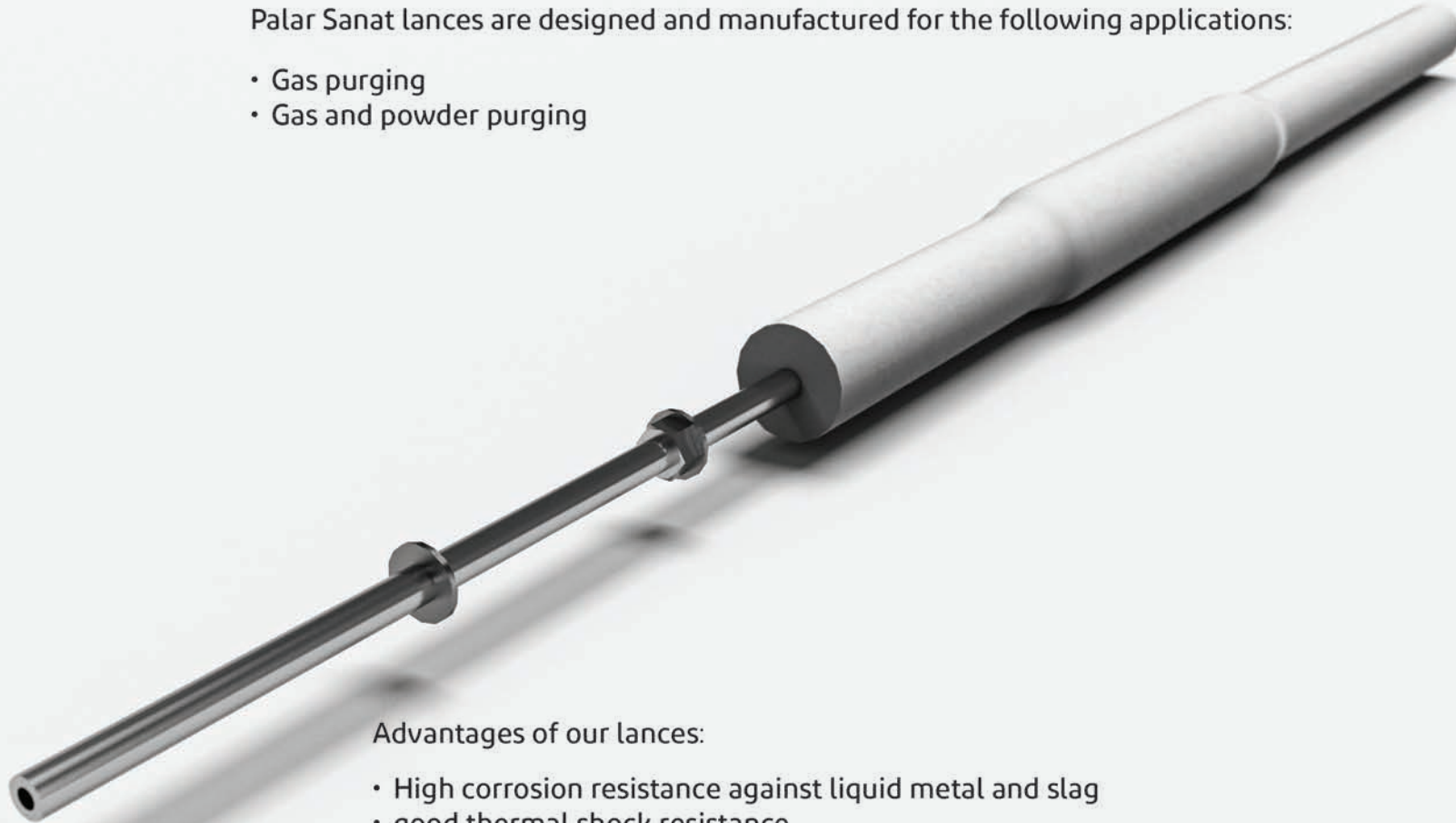

Advantages of our lances:

- High corrosion resistance against liquid metal and slag
- good thermal shock resistance
- Long life time

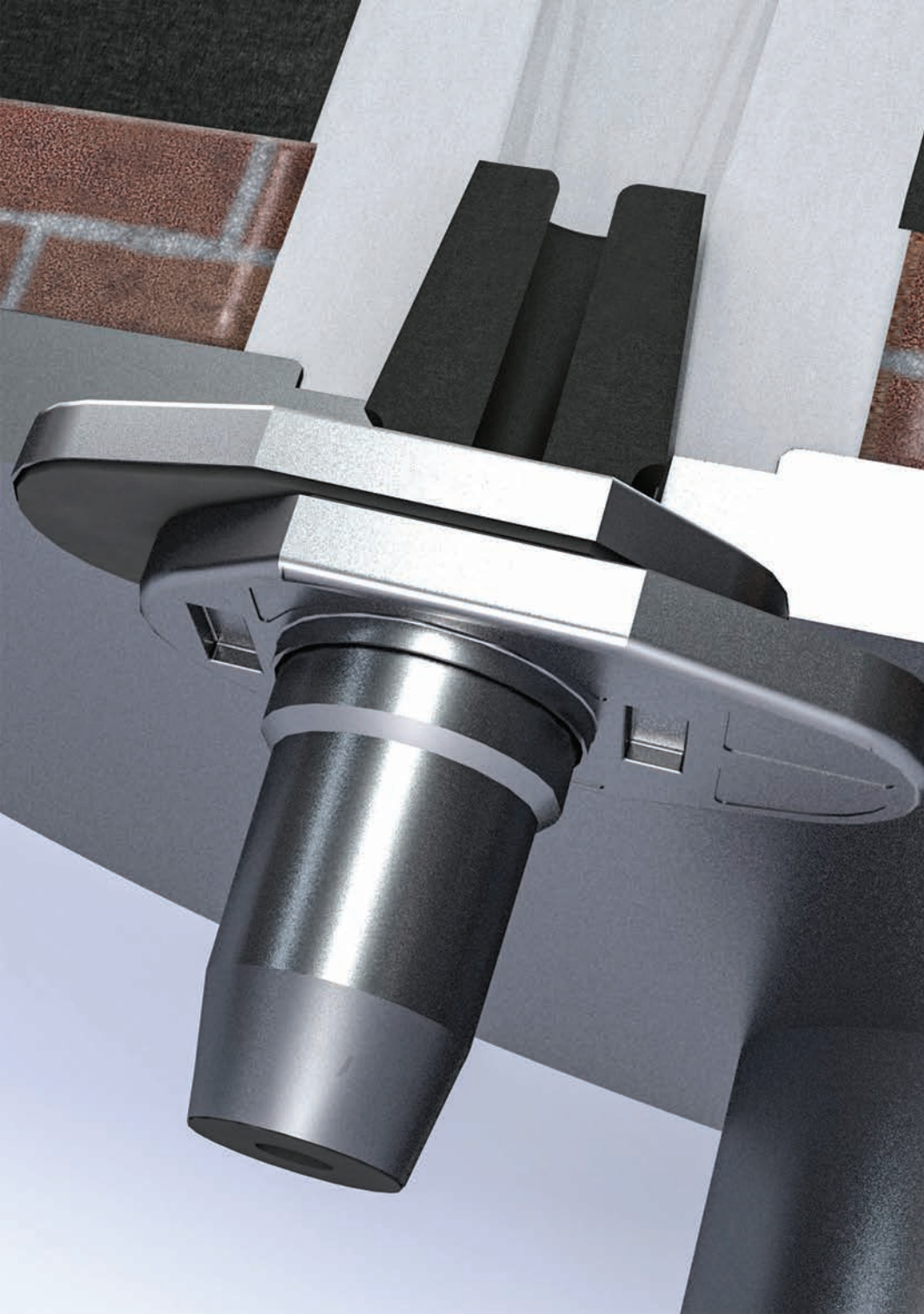

LADLE GATE REFRACTORIES

Ladle Gate is located at the bottom of the Ladle for more efficient management of molten steel flow
The main roles of the Ladle gate refractories are:

- To adjust the steel flow from Ladle to Tundish
- To minimize the risk of steel re-oxidation

Regardless of Ladle mechanisms and Ladle capacity, Palar Sanat produces and supplies all types of the Ladle gate refractory like Well Block, Inner Nozzle, Collector Nozzle, Slide Gate, and different types of mortars.

Well Block

The main function of the Well Block is to fix the position of the Nozzle in the Ladle & facilitate the detachment and installment of the Nozzle.

Palar Sanat's Well Blocks are made from high alumina raw materials like Plc97, PLC93sp, and PLC95sp.

Our products have high mechanical strength especially at high temperatures which caused a long lifetime during application.

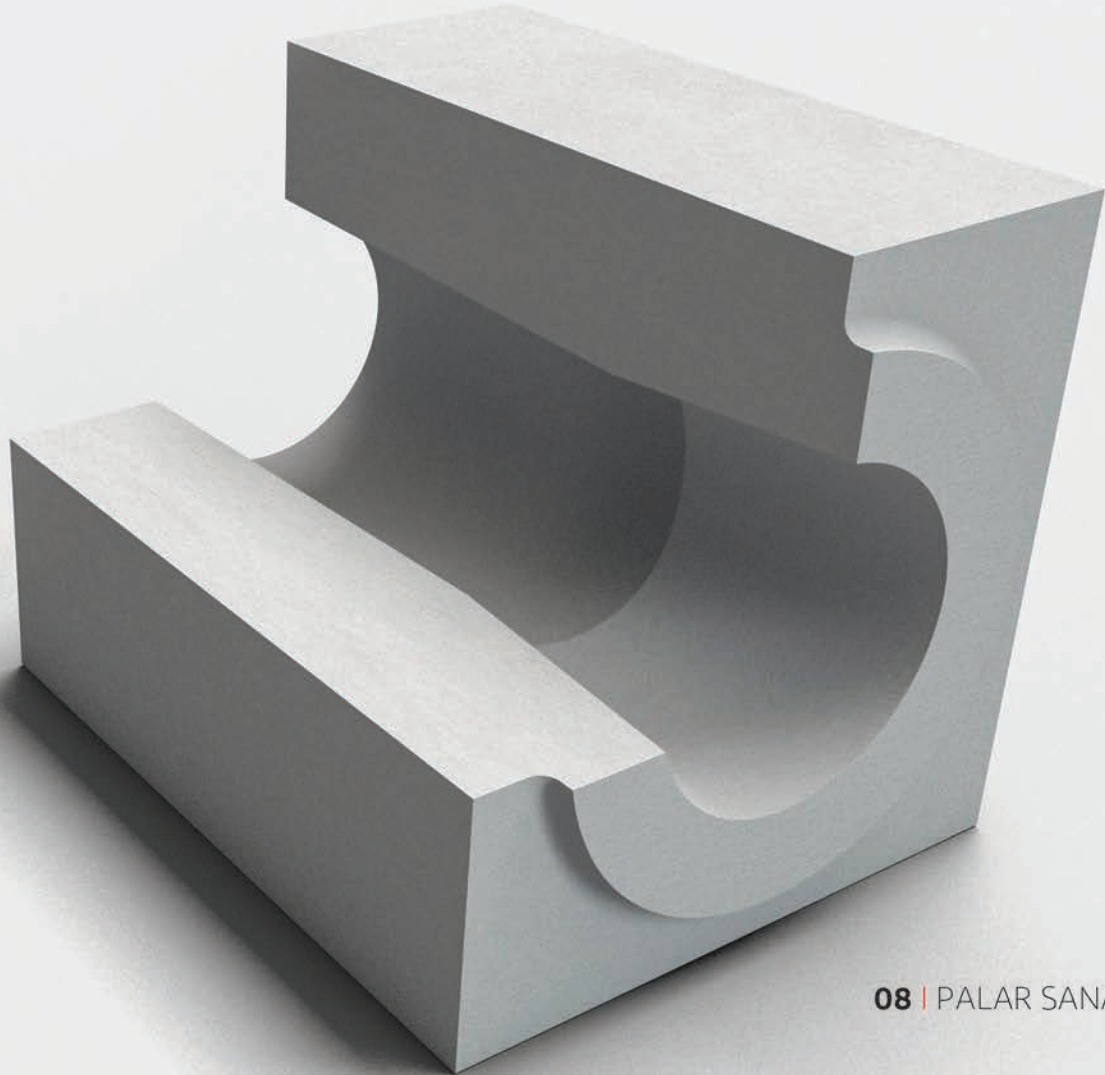

Inner Nozzle and Collector Nozzle

Ladle Inner and Collector Nozzle plays a critical role in steel production process. They control the flow of steel from Ladle to Tundish. In order to achieve superior resistance to thermal shock, erosion, oxidation, and long service, Palar Sanat develops Inner and Collector Nozzle products based on the optimized technology and the tightest compacting of the material.

PSC Nozzles are offered in two types of casting and pressing:

Type		Casting		Pressing		
Brand		PLC97	PLC92	PAL-C(80-90)	PAL-CZ(3-12)	PMG-C(80-90)
Chemical composition (%)	Al ₂ O ₃	80-90	92	80-90	75-85	0-14
	MgO	-	4-5	-	-	80-90
	C	3-7	-	3-7	3-7	3-7
	Zr	-	-	-	3-12	-
Bulk density(g/cm ³)		3.05	3.05	3-3.1	3.05-3.15	3-3.1
Cold crushing strength(kgf/cm ²)		≥900	≥950	1200-1700	1300-1800	1100-1500

Inner nozzle



Collector nozzle



Ladle Slide Gate plate

Ladle Slide Gate plates are one of the critical flow control devices for casting molten steel in the steel-making process. In 2016 Palar Sanat's R&D department, using the highest technologies and its experience in the refractories field, designed and developed Ladle Slide Gate Plates in different sizes and analyses (Al₂O₃-C, Al₂O₃-ZrO₂-C, and Al₂O₃-MgO-C) to meet all steel making planets requirements. PSC Slide Gate Plates must have uniform structure, high density, and low porosity, which will greatly improve the performance and service life of the refractories to achieve a high safety level.

Type		AL-C	AL-C-ZR	AL-C-MG
Brand		PAL-C(80-90)	PAL-CZ(3-12)	PMG-C(80-90)
Type		AL-C	AL-C-ZR	AL-C-MG
Chemical composition (%)	Al ₂ O ₃	80-90	75-85	0-14
	MgO	-	-	80-90
	C	3-7	3-7	3-7
	Zr	-	3-12	-
Balk density(g/cm ³)		3-3.1	3.05-3.15	3-3.1
Cold crushing strength (kgf/cm ²)		1200-1700	1300-1800	1100-1500



Assembled Slide Gate and Collector Nozzle

The lower Slide Gate and Collector Nozzle are usually joined together at the steel-making site, with mortar and fixture.

Since the product is used at a very high-temperature place (bottom of the Ladle), this joint may not be establishing properly and as a result, causes irreparable damages.

To minimize the risks during consumption and make it easy to use, Palar Sanat has integrated the lower Slide Gate and the Collector Nozzle into the production line.



LADLE FILLING MASS

Well Block is filled with filler sand as a thermal insulating barrier that prevents direct contact between molten metal and the Slide Gate system of the Ladle. Effective filling sand must provide a high free opening rate, impacting on increased productivity, quality, and steel re-oxidation. Palar Sanat filling sand is made up of high-quality raw materials that can be used on different Ladles.

Brand		PALFILL- Cr36	PALFILL- Cr30	PALFILL- Cr10
Chemical composition (%)	Al ₂ O ₃	9-11	10-12	2-5
	Cr ₂ O ₃	34-38	28-32	10-12
	SiO ₂	20-22	22-26	72-77
	Fe ₂ O ₃	13-16	14-18	2-6
	MgO	11-13	12-16	3-5
	C	≤1	≤1	≤1



TUNDISH

Tundish Plaster
Tundish gate refractories
Tundish Precast Shapes

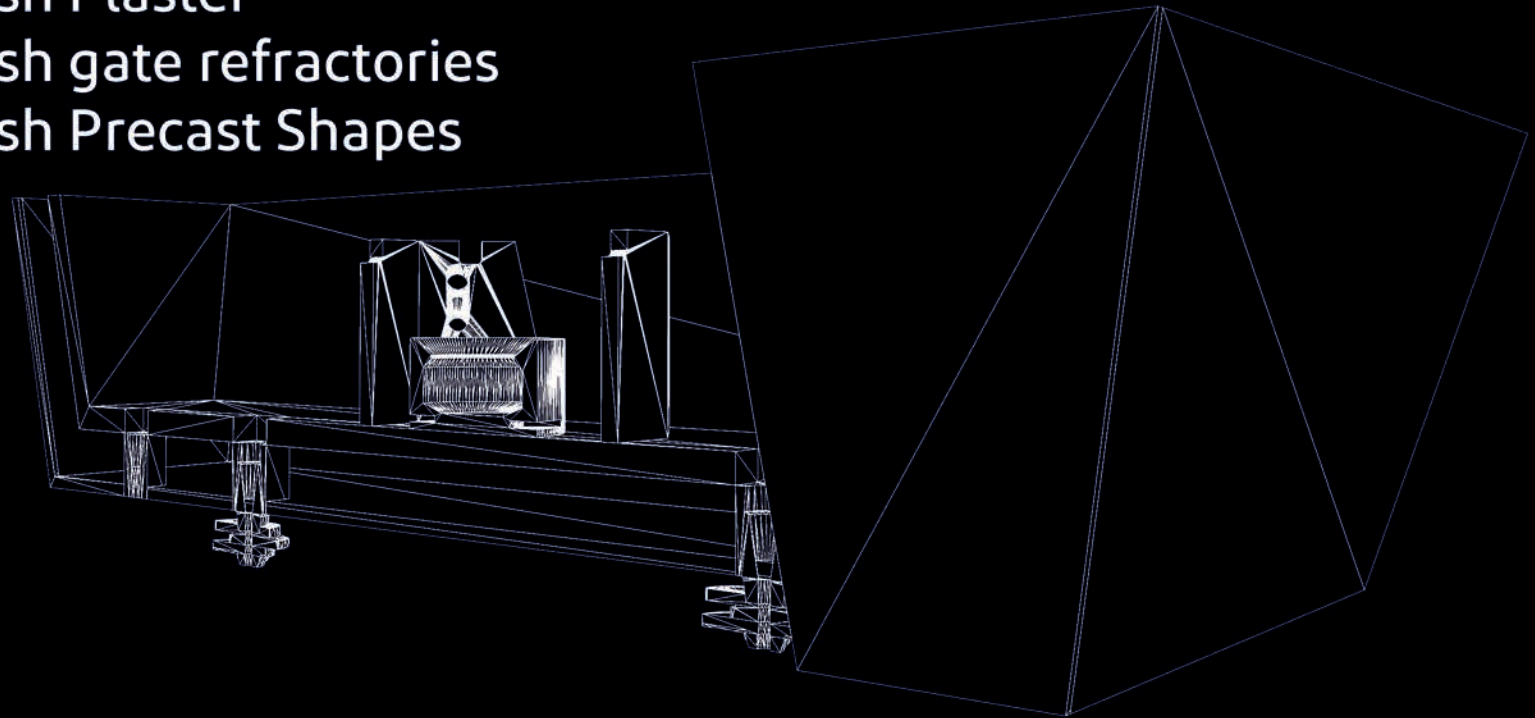

Tundish Plaster

Tundish is used as an intermediary between the Ladle and the mold, In the continuous casting of steel. Typically, Tundish linings are composed of three layers. Working lining or plaster is the third layer that is exposed directly to the steel. The main task of plaster is to provide insulation, an inert barrier between the steel and other layers, and act as a separation layer for easy deskinning.

Palar Sanat Plaster made from high quality magnesia and classified in three group: high sequence (HQS), medium sequence (MQS) and low sequence (LQS).

Brand		HQS F	HQS 800	HQC 760	HQS 630	MQS	MQS F	LQS
Chemical composition (%)	MgO	78	92-94	88	82	75	78	62
	Al ₂ O ₃	2.5	1.5	2	2	2.5	5	7.5
	C	10	2.5	3	4	11	6	13
Balk density(g/cm ³)		13 - 17	13 - 17	13 - 17	13 - 17	13 - 17	13 - 17	13 - 17
Apparent Porosity		32-40	32-40	32-40	32-40	32-40	32-40	32-40



TUNDISH GATE REFRACTORIES



Tundish Nozzle & Well Block

In continuous casting, melt flow is poured uninterruptedly from Tundish into the mold. There are several different methods to control the flow such as Tundish Nozzle and Well Block.

Palar Sanat Tundish Nozzles and Well Blocks made from high alumina Castables (with or without chrome). zirconia Inner Nozzle (often referred to as a zirconia insert) is also used in the middle of the Tundish Nozzles to archive thermal shock stability. High chemical and erosion resistance are the features of our products.

		insert		Tundish Nozzle body or Well Block		
Type		96 zr	76 zr	Plc 93	Plc 94 cr	Plc 97
Chemical composition (%)	Al ₂ O ₃	--	--	92-94		97
	Cr ₂ O ₃	--	--	-	94	-
	Zr	96	76	-	3.5	-



Tundish Slide Gate

Today, Slide Gate is an essential part of the advanced steel smelting process. The most important role of this product is controlling the flow rate of molten and prevent the formation of undesired instabilities that can cause level fluctuation. In Palar Sanat, the selection of raw materials for Slide Gate has been done by considering conditions such as the type of Tundish and steel, casting time, molten steel temperature, amount of steel, and operating conditions such as thermal shock and abrasion.

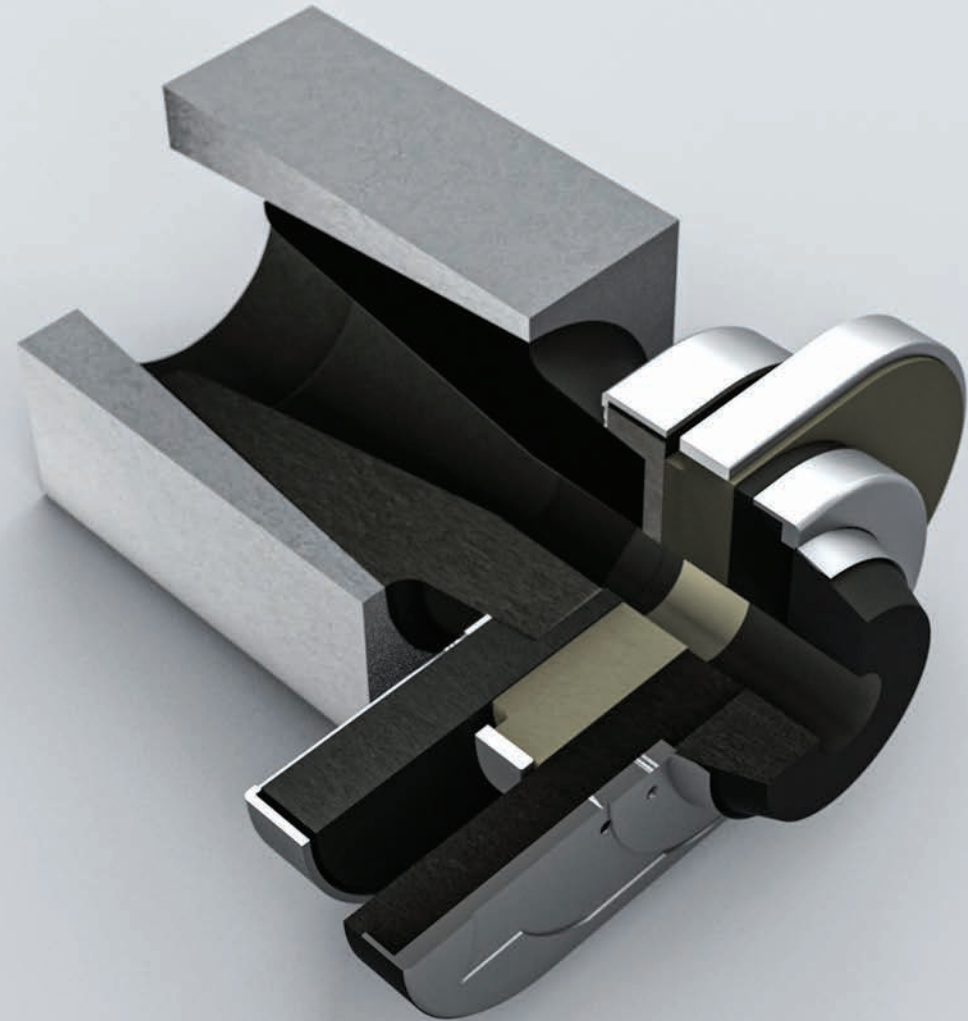

Tundish Precast Shapes

Impact Pot, Impact Pad and Slag Dam are just some of the refractory precast shapes in Tundish. Impact Pots & Pads are used for the purpose of minimizing steel flow turbulence within the Tundish. Slag Dam is an auxiliary product in the Tundish that prevents entering slag into molds which improves steel quality. They have different designs depending on the customer's order. By using Palar Sanat Tundish Precast Shapes, you will guarantee the safety and longevity of the Tundish and improving melting quality.

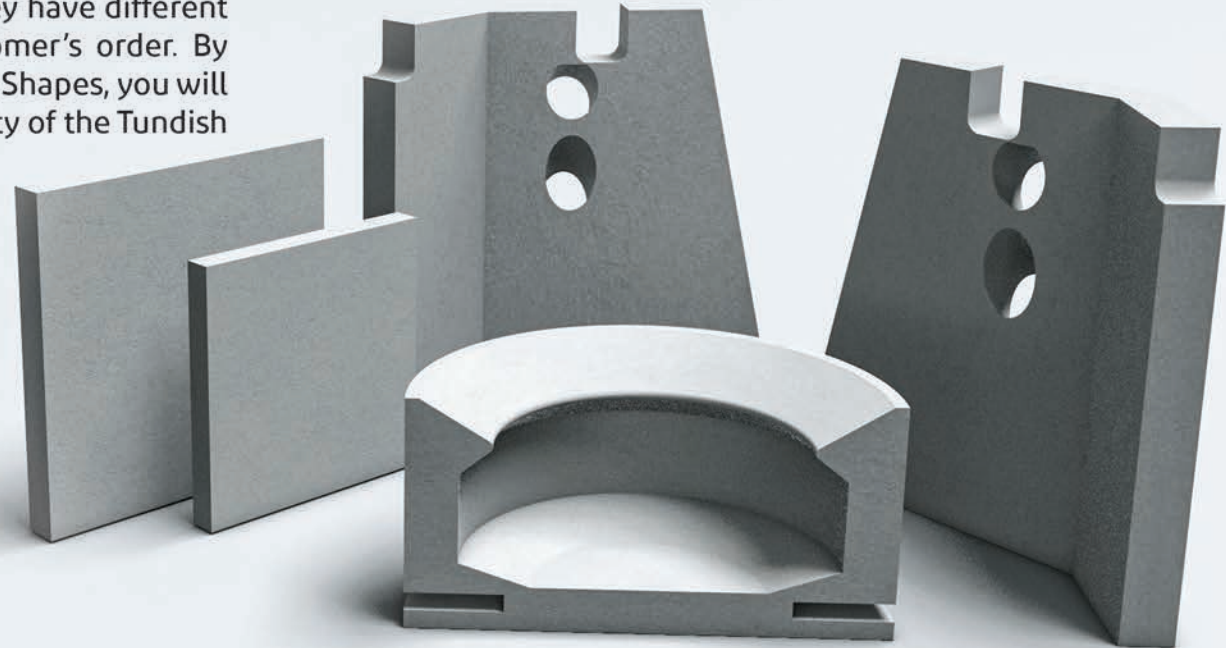

ELECTRIC ARC FURNACE

EAF Roof

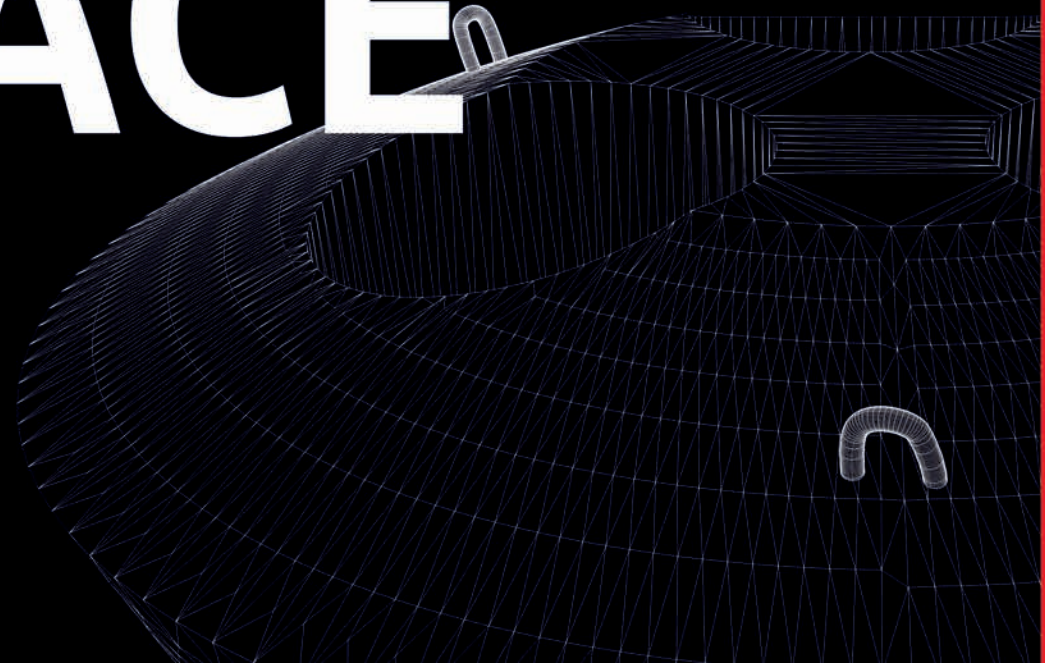

EAF Roof

Electric Arc Furnace (EAF) is a steelmaking furnace, in which scrap metal is melted by using an electrical and chemical process.

Palar Sanat's EAF Roof, can be design depending on the steelmaking conditions and customers' needs. Our product is made of special high alumina Castable with or without chrome that can provide very good thermal shock resistance, excellent erosion and corrosion resistance, good volume stability, and long service life.

BRAND		PLC97	PLC93sp	PLC94cr	PLC97cr
Chemical composition (%)	Al ₂ O ₃	97	93	94	97
	MgO	-	4-5	-	-
	Cr	-	-	4	1
Cold crushing strength (kgf/cm ²)	110°C×5h	>600	>600	>650	>650
	1200°C×5h	>900	>900	>1100	>1100

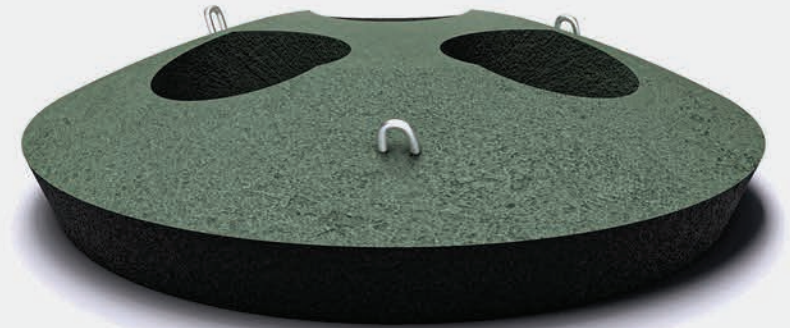

REFRACTORY ALUMINA MIXES AND MORTARS

Insulating
Gunning
Regular Cement Castable
Low Cement Castable
Ultra-low Cement Castable
Mortar

Palar Santa's alumina mixes are produced in regular cement, low cement, and ultra-low cement with high-quality raw materials by fully automatic and high-precision systems. Different types of Gunning and Insulating mixes are also produced in high quality.

These mixes can be used widely in metallurgical, petrochemical, and other industries depending on customers' needs and working conditions.

Insulating	Gunning	Regular cement	Low cement					Ultra-low cement
PLW	PAL-GUN	PRC	PLC	PLC-SF	PLC-CR	PLC-SP	PLC ANDO	PULC
PLW-30	PALgun-60	PRC-50LI	PLC-50	PLC-80sf	PLC-85cr	PLC-85sp	PLC-62ando	PULC-60
PLW-35	PALgun-70	PRC-55	PLC-60	PLC-85sf	PLC-90cr	PLC-91sp	PLC-77ando	PULC-70
PLW-30li	PALgun-80	PRC-60	PLC-70	PLC-90sf	PLC-94cr	PLC-93sp	PLC-85ando	PULC-80
PLW-35li	PALgun-85	PRC-70	PLC-80	PLC-95sf	PLC-97cr	PLC-95sp		PULC-90
		PRC-80	PLC-85	PLC-97sf				PULC-94
		PRC-85	PLC-90	PLC -98.5sf				PULC-97
		PRC-90	PLC-92					
		PRC-95	PLC-94					
		PRC-96.5	PLC-97					
			PLC-98					

Insulating

Palar Sanat's Insulating Castables which are known as PLW provide high refractoriness, low thermal conductivity, and good wear resistance.

BRAND		PLW-30	PLW-35	PLW-30li	PLW-35li
Chemical composition (%)	AL ₂ O ₃	30	35	30	35
	SiO ₂	42	38	42	38
	Fe ₂ O ₃	7	7	2.5	2.5
	CaO	15	15	12	12
Bulk density (g/cm ³)		1.3	1.4	1	1.2
Maximum service temperature (°C)		1000	1100	1100	1200
Cold crushing strength (kgf/cm ²)	110°C×5h	30	50	40	60
	1200°C×5h	20	30	30	40

Gunning

Palar Sanat has developed PAL-GUN which is a series of mixes from high-quality raw materials. High adhesive strength, low rebound rate, good sintering, good erosion, and corrosion resistance are the merits of these products.

BRAND		PAL-GUN 60	PAL-GUN 70	PAL-GUN 80	PAL-GUN 85
Chemical composition (%)	AL ₂ O ₃	60	70	80	85
	SiO ₂	30	21	8	6
	Fe ₂ O ₃	2.5	2.2	18	13
	CaO	6.5	6.5	6.5	6.3
Bulk density (g/cm ³)		2.1	2.7	2.7	2.8
Cold crushing strength (kgf/cm ²)	110°C×5h	400	450	470	470
	1200°C×5h	250	300	300	400

Regular Cement Castable

Palar Sanat's Regular Cement Castables (PRC) are made of different percentages alumina so they can be used in a wide range, according to customers' needs.

BRAND		PRC 50L	PRC 55	PRC 60	PRC 70	PRC 80	PRC 85	PRC 90	PRC 95	PRC 97
Chemical composition (%)	AL ₂ O ₃	50	55	60	70	80	85	90	95	97
	SiO ₂	25	25	31	21	11	9	6	1	0.5
	Fe ₂ O ₃	2.5	6	2.8	2.5	2.5	2.5	1.5	0.8	0.2
	CaO	10	12	4-6.5	4-6.5	4-6.5	4-6.5	4-6.5	4-6.5	3
Bulk density (g/cm ³)		2.2	2	2.3	2.4	2.5	2.5	2.6	2.8	2.9
Cold crushing strength (kgf/cm ²)	110°C×5h	400	350	400	450	470	470	480	500	530
	1200°C×5h	250	200	250	300	300	300	350	380	400



Low Cement Castable

Palar Sanat developed the low cement Castables (maximum 5 - 6 %) with high-tech additives for use in various working conditions. This group of Castables are classified in high alumina (PLC), self-flow (PLC_SF), chrome content (PLC_CR), spinel content (PLC_SP), and andalusite content (PLC_AN).

PLC (Palar Low Cement Castable)

BRAND		PLC -50	PLC -60	PLC -70	PLC -80	PLC -85	PLC -90	PLC -92	PLC -94	PLC -97	PLC -98
Chemical composition (%)	Al ₂ O ₃	50	60	70	80	85	90	92	94	97	98.5
	SiO ₂	37	28	19	12	9	4	3	3	0.1	0.1
	Fe ₂ O ₃	3	3	2.8	2.8	2.8	2	15	1	0.1	0.1
	CaO	15-2.2	15-2.2	15-2.2	15-2.2	15-2.2	15-2.2	15-2.2	15-2.2	15-2.2	15
Bulk density (g/cm ³)		2.25	2.3	2.35	2.4	2.6	2.8	2.8	2.9	3	3.1
Cold crushing strength (kgf/cm ²)	110°C×5h	550	550	500	600	650	700	700	750	800	850
	1200°C×5h	600	650	650	700	750	750	600	650	650	700

PLC-Sf (Palar Low Cement Castable- Self Flow)

BRAND		PLC-80sf	PLC-85sf	PLC-90sf	PLC-95sf	PLC-97sf	PLC-98.5sf
Chemical composition (%)	AL ₂ O ₃	80	85	90	95	97	98.5
	SiO ₂	12	9	6	2	0.1	0.1
	Fe ₂ O ₃	1.5	1	1	0.1	0.1	0.1
	CaO	1.5-2.2	1.5-2.2	1.5-2.2	1.5-2.2	1.5-2.2	1.5-2.2
Bulk density (g/cm ³)		2.6	2.7	2.8	2.9	3	3.1
Cold crushing strength (kgf/cm ²)	110°C×5h	600	650	680	700	750	700
	1200°C×5h	560	580	600	630	650	800



PLC-SP (Palar Low Cement – Spinel Content)

BRAND		PLC-85SP	PLC-91SP	PLC-93SP	PLC-95SP
Chemical composition (%)	AL ₂ O ₃	85	90	93	95
	SiO ₂	3.5	2	0.2	0.2
	Fe ₂ O ₃	0.9	0.5	0.1	0.1
	CaO	1.5-2.2	1.5-2.2	1.5-2.2	1.5-2.2
	MgO	5.5	4	5	3
Bulk density (g/cm ³)		2.9	2.9	2.95	2.95
Cold crushing strength (kgf/cm ²)	110°C×5h	750	800	800	800
	1200°C×5h	900	1000	1100	1100

PLC-Cr (Palar Low Cement – Chromite Content)

BRAND		PLC-85Cr	PLC-90Cr	PLC-94Cr	PLC-97Cr
Chemical composition (%)	AL ₂ O ₃	84	90	94	97
	SiO ₂	6	2.5	0.5	0.5
	Fe ₂ O ₃	1.6	0.8	0.1	0.1
	CaO	1.5-2.2	1.5-2.2	1.5-2.2	1.5-2.2
	Cr ₂ O ₃	1	2.5	3.5	1.5
Bulk density (g/cm ³)		2.7	2.9	3	3
Cold crushing strength (kgf/cm ²)	110°C×5h	750	800	800	800
	1200°C×5h	850	1100	1100	1100

PLC-AN (Palar Low Cement – Andolozite Content)

BRAND		PLC-62ando	PLC-77ando	PLC-85ando
Chemical composition (%)	AL ₂ O ₃	62	77	85
	SiO ₂	39	19	11
	Fe ₂ O ₃	1.2	1.5	1
	CaO	2.4	2.4	2.4
Bulk density (g/cm ³)		2.4	2.6	2.7
Cold crushing strength (kgf/cm ²)	110°C×5h	600	750	800
	1200°C×5h	650	800	900

Ultra-low Cement Castable

Palar Sanat developed ultra-low cement Castables with refractory aggregate, powder, and less than 1.2% alumina cement. These Castables have a high refractory temperature, high strength, and good slag resistance, due to the low amount of cement.

BRAND		PLC -55	PLC -60	PLC -70	PLC -80	PLC -90	PLC -92	PLC -94	PLC -97	PLC -98
Chemical composition (%)	AL ₂ O ₃	55	60	70	80	90	92	94	97	98.5
	SiO ₂	38	29	11	11	4	3	3	0.1	0.1
	Fe ₂ O ₃	2.5	1.5	2.8	1.8	1.5	1.2	1	0.1	0.1
	CaO	1.2	1.2	1.1	1.1	1	0.8	0.7	0.6	0.6
Bulk density (g/cm ³)		2.3	2.5	2.6	2.7	2.8	2.8	2.9	2.95	3
Cold crushing strength (kgf/cm ²)	110°C×5h	350	350	400	450	450	480	500	530	550
	1200°C×5h	650	700	750	800	850	880	850	880	900

Mortar

Palar Sanat mortars are classified into two groups: Air-setting (PAL-MOR) and heat-setting (PAL-BAND).

Air-setting mortars (PAL-MOR) take a rigid set upon air drying and can be used generally for various purposes depending on the needs.

Heat-setting mortars (PAL-BAND) are set at high temperatures by sintering or developing a ceramic bond. This series of mortars are produced with or without chrome and carbon. They are specialized for use in Ladles and especially for Ladle gate systems.

MORTAR	
PAL-MOR	PAL-BAND
PAL mor 45	PAL BAND 88cr
PAL mor 60	PAL BAND 77cr
PAL mor 75	PAL BAND 83crc
PAL mor 90	PALBOND 94r



CUSTOMERS



Mobarakeh Steel Company



Esfahan Steel Company



Khouzestan Steel Company



Isfahan Alloy Steel Complex



Iran Alloy Steel company



Vian Steel Complex



Saba Steel Company



West Alborz Steel company



Arfa Iron and steel



Pasargad Steel



Khorasan steel



South Kaveh Steel company (SKS)



Khazar steel company



Sirjan Iranian Steel company



Chadormalu Mining and Industrial Company



Mashiz Bardsir Steel Industries



Sirjan Steel World company



Iran National Steel Industrial Group



Bonab Steel Industry Complex



Hormozgan Steel company



Nazmavaran Steel company



Zarand Iranian Steel company





IT'S OUR POWER



World-class production with Iranian knowledge

 PALAR SANAT FACTORY
10th Street-Razi Industrial Zone
ISFAHAN-IRAN

 palarsanat
 palarsanat.co

